

# WATT / VAR TRANSDUCER

**LPWK101**

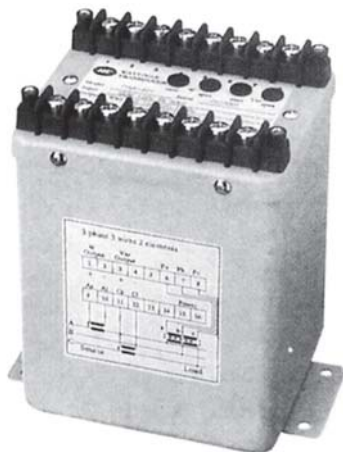

- ⊙ High accuracy 0.07% rd + 0.03% ro
- ⊙ Excellent long term stability
- ⊙ Outstanding over capability and temperature performance
- ⊙ Wide selection of input / output ranges
- ⊙ Meets ANSI C37.90 (1989) and BEAMA No. 219 tests
- ⊙ High magnetic field immunity
- ⊙ Real watt - able to measure distorted waveform
- ⊙ Isolated between watts and vars output

## Order form

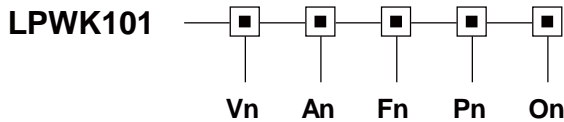

Example : LPWK101-V1-A2-F2-P1-O3

## Input & Output parameters

<b>Vn</b> : Voltage input	<b>Vn</b> rating range	<b>V1</b>	<b>V2</b>	<b>V3</b>	<b>Vy</b> Specified	<b>On</b> : Output		
		120 V 0 - 150 V	240 V 0 - 300 V	480 V 0 - 600 V		<b>O1</b> 0 - 1 mA	<b>O2</b> 0 - 20 mA	<b>O3</b> 4 - 20 mA
<b>An</b> : Current input	<b>An</b> rating range	<b>A1</b>	<b>A2</b>	<b>A3</b>	<b>Ay</b> Specified	<b>O4</b>	<b>O5</b>	<b>O6</b>
		1 A 0 - 1.5 A	5A 0 - 7.5 A	10A 0 - 15 A		0 - 1 V	0 - 5 V	0 - 10 V
<b>Fn</b> : Frequency input	<b>Fn</b> rating range	<b>F1</b>	<b>F2</b>		<b>Fy</b> Specified	<b>O7</b>	<b>Oy</b>	
		50 Hz 48 - 52 Hz	60 Hz 58 - 62 Hz			2 - 10 V	Specified	
<b>Pn</b> : Auxiliary power	<b>Pn</b> rating range	<b>P1</b>	<b>P2</b>	<b>Ps</b>	<b>Py</b> Specified	<b>Py</b> : DC24 / 48 / 125 V ± 15% or other range under specified		
		AC 120 V 120 V ± 15%	AC 240 V 240 V ± 15%	Internal Powered				

Model	Application system	Std. calibration vs output full span ( Watt / Var ) = D								
		V1 = 120 V			V2 = 240 V			V3 = 480 V		
		1A	5A	10A	1A	5A	10A	1A	5A	10A
LPWK101	1E 1 phase 2 wires	100	500	1K	200	1K	2K	400	2K	4K

## Note

1. Standard output calibration  
bipolar 0 to ± 1mA for 0 to ± D Watts or Vars  
4-12-20mA for -D to 0 to +D Watts or Vars
2. External power mode suitably for all output types  
Internal power mode, only suitably for 0-1mA / 0-20mA / 0-1V / 0-5V / 0-10V output



**HSIANG CHENG ELECTRIC CORP.**

4F., No.11, Ln. 235, Baoqiao Rd., Xindian Dist., New Taipei City 231, Taiwan

TEL : 886-2-2917-5865~9

E-mail : expo.sales@hc.com.tw

FAX : 886-2-2917-3946

http://www.hc.com.tw

## Specification

<b>Accuracy ( 23 ± 3°C )</b>	0.07% reading / PF ± 0.03% RO		
<b>Maximum output load</b>	DC current mode : maximum 10V drop DC voltage mode : maximum 5mA drive		
<b>Dielectric strength</b>	AC 2KV 1 minute between terminals; AC 2.6KV 1 minute / terminals to case		
<b>Surge and impulse test</b>	ANSI C37.90 / 1989, IEC 255-3 (1989) 4KV 1.2 x 50us		
<b>Maximum input over</b>	Current related input		Voltage related input
	1A / 5A	10A	
	4 x rated / continuous	2 x rated / continuous	1.5 x rated / continuous
	10 x rated / 10 seconds	25 x rated / 1 second	2 x rated / 10 seconds
	50 x rated / 1 second	50 x rated / 0.5 second	
	80 x rated / 0.5 second		
<b>Input burden</b>	Current less 0.2 VA; voltage less 0.1 VA		
<b>Response time &amp; ripple</b>	≤ 400 ms for step change 0-99% ripple less 0.5% ro peak to peak		
<b>Frequency</b>	50 ± 2 Hz; 60 ± 2 Hz		
<b>Waveform</b>	Watt - 2% 3rd, Var - sinusoidal		
<b>Stability</b>	Temperature range ( 20 to 26°C ) long term stability / year		
	Maximum 60 ppm / °C	less 0.2% draft / year typically	..... LPW
	Maximum 70 ppm / °C	less 0.2% draft / year typically	..... LPK
<b>Storage condition</b>	Temperature range -25 to 70°C, RH 20 to 95% non condensed		
<b>Operating condition</b>	Temperature range -20 to 65°C, RH 0 to 99% non condensed		
<b>Magnetic field effect</b>	< 0.01% under 100 ampere turns at 1M center		
<b>Power dissipation</b>	< 7 VA		

## Terminal Connection

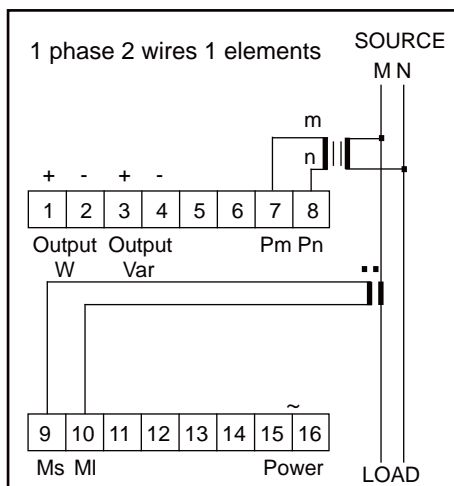

DC power option for terminal 15 (+), 16 (-)

## Dimension

