

WATT / VAR TRANSDUCER

LPWK211

- ⊙ High accuracy 0.07% rd + 0.03% ro
- ⊙ Excellent long term stability
- ⊙ Outstanding over capability and temperature performance
- ⊙ Wide selection of input / output ranges
- ⊙ Meets ANSI C37.90 (1989) and BEAMA No. 219 tests
- ⊙ High magnetic field immunity
- ⊙ Real watt - able to measure distorted waveform
- ⊙ Isolated between watts and vars output

Order form

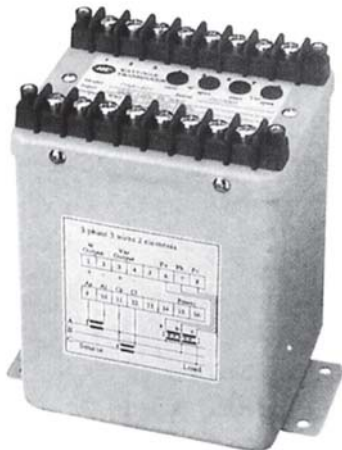
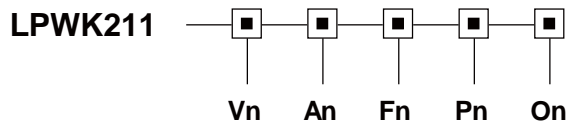

Example : LPWK211-V1-A2-F2-P1-O3

Input & Output parameters

Vn : Voltage input	Vn rating range	V1	V2	V3	Vy Specified	On : Output		
		120 V 0 - 150 V	240 V 0 - 300 V	480 V 0 - 600 V		O1 0 - 1 mA	O2 0 - 20 mA	O3 4 - 20 mA
An : Current input	An rating range	A1	A2	A3	Ay Specified	O4	O5	O6
		1 A 0 - 1.5 A	5A 0 - 7.5 A	10A 0 - 15 A		0 - 1 V	0 - 5 V	0 - 10 V
Fn : Frequency input	Fn rating range	F1	F2		Fy Specified	O7	Oy	
		50 Hz 48 - 52 Hz	60 Hz 58 - 62 Hz			2 - 10 V	Specified	
Pn : Auxiliary power	Pn rating range	P1	P2	Ps	Py Specified	Py : DC24 / 48 / 125 V ± 15% or other range under specified		
		AC 120 V 120 V ± 15%	AC 240 V 240 V ± 15%	Internal Powered				

Model	Application system	Std. calibration vs output full span (Watt / Var) = D										
		Watt / Var	Elements - Connection	V1 = 120 V			V2 = 240 V			V3 = 480 V		
				1A	5A	10A	1A	5A	10A	1A	5A	10A
LPWK211	2.5E 3 phase 4 wires, unbalance		300	1.5K	3K	600	3K	6K	1.2K	6K	12K	

Note

- Standard output calibration
bipolar 0 to ± 1mA for 0 to ± D Watts or Vars
4-12-20mA for -D to 0 to +D Watts or Vars
- External power mode suitably for all output types
Internal power mode, only suitably for 0-1mA / 0-20mA / 0-1V / 0-5V / 0-10V output

HSIANG CHENG ELECTRIC CORP.

4F., No.11, Ln. 235, Baoqiao Rd., Xindian Dist., New Taipei City 231, Taiwan

TEL : 886-2-2917-5865~9

E-mail : expo.sales@hc.com.tw

FAX : 886-2-2917-3946

<http://www.hc.com.tw>

Specification

Accuracy (23 ± 3°C)	0.07% reading / PF ± 0.03% RO		
Maximum output load	DC current mode : maximum 10V drop DC voltage mode : maximum 5mA drive		
Dielectric strength	AC 2KV 1 minute between terminals; AC 2.6KV 1 minute / terminals to case		
Surge and impulse test	ANSI C37.90 / 1989, IEC 255-3 (1989) 4KV 1.2 x 50us		
Maximum input over	Current related input		Voltage related input
	1A / 5A	10A	
	4 x rated / continuous	2 x rated / continuous	1.5 x rated / continuous
	10 x rated / 10 seconds	25 x rated / 1 second	2 x rated / 10 seconds
	50 x rated / 1 second	50 x rated / 0.5 second	
	80 x rated / 0.5 second		
Input burden	Current less 0.2 VA; voltage less 0.1 VA		
Response time & ripple	≤ 400 ms for step change 0-99% ripple less 0.5% ro peak to peak		
Frequency	50 ± 2 Hz; 60 ± 2 Hz		
Waveform	Watt - 2% 3rd, Var - sinusoidal		
Stability	Temperature range (20 to 26°C) long term stability / year		
	Maximum 60 ppm / °C	less 0.2% draft / year typically LPW
	Maximum 70 ppm / °C	less 0.2% draft / year typically LPK
Storage condition	Temperature range -25 to 70°C, RH 20 to 95% non condensed		
Operating condition	Temperature range -20 to 65°C, RH 0 to 99% non condensed		
Magnetic field effect	< 0.01% under 100 ampere turns at 1M center		
Power dissipation	< 7 VA		

Terminal Connection

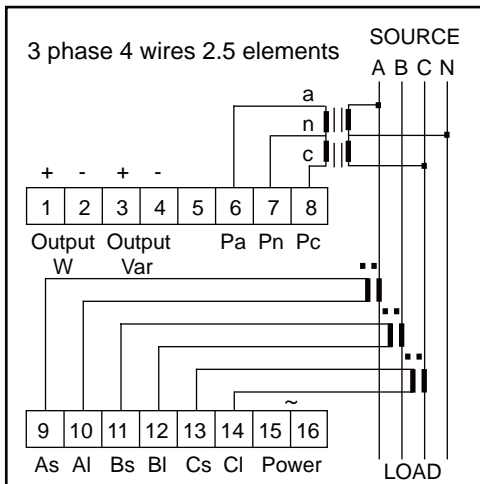

DC power option for terminal 15 (+), 16 (-)

Dimension

