

DC Isolating Transducer

USPD-2



- ⊙ Standard output with 0 - 1 mAdc; Option on request
- ⊙ Dual isolated outputs eliminating ground loop effect
- ⊙ AC 1800V input / output / isolation meets power series requirement
- ⊙ Meets IEEE SWC test

Specification

1.Accuracy 0.25% RO / 23 ± 3°C

2.Input (each element)

Range	0 - 50 / 0 - 100 / 0 - 200 / 500mV 0 - 1 / 0 - 2 / 0 - 5 / 1 - 5 / 0 - 10 / 2 - 10V 0 - 1 / 0 - 2 / 0 - 5 / 0 - 10 / 0 - 20 / 4 - 20 / 0 - 50 / 10 - 50 mA
Input resistance	Voltage mode > 1 Megaohm; current mode < 1V / max. rated current (mA)
Protection	Full protection for SURGE, EMI & RFI

3.Output (Isolated with input ; Dual outputs isolated each other > DC 600V isolation)

Range	DC 0 - 1 / 0 - 5 / 0 - 10 / 0 - 20 / 4 - 20 / 0 - 50 / 10 - 50 mA DC 0 - 1 / 0 - 5 / 1 - 5 / 0 - 10 / 2 - 10V
Standard calibration	0 - 1mA vs required input range
Option...specified	
Drive ability	> 10K ohm for 0 - 1mA standard output > 10V for current output mode > 10mA for voltage output mode
Output impedance	> 30 Mega ohm
Response time	< 400 ms from 0 - 99% RO at operating
Ripple	< 0.5% P- P RO
Long term stability	< 0.5% RO per year
Temperature stability	< 0.015% per degree C, from 0 - 55°C
Adjustment	Span, zero ± 15% ro minimum
Protection	No damage ... open or short; full protection of SURGE, EMI, RFI
Magnetic effecton	< 0.04% at center 400 A - T / M

4. Operation condition

Environment

Temperature -5 - 60°C

Humidity 20 - 99% RH non condensed

Elevation Under 3000 meters

Magnetic field 500 A - T / M

Dielectric strength 4KV AC rms 1 minute between input / output / power / case IEC

Impulse test ANSI C37.90/1989, IEEE 587/1983,
IEC 255-3, 6KV (1.2 x 50 us), 3KA (8 x 20 us) current only

Surge test (ring wave) IEEE587/1983 (3KV - 0.5us / 100KHz)

IEC 255-3 (2.5KV - 0.25ms / 1MHz)

Power supply LO: DC 24 - 60V ± 20%

HI : AC 80 - 260V @40 - 70Hz / DC 80 - 330V

Dissipation Max. 12VA for AC / 10W for DC

Terminal Connection

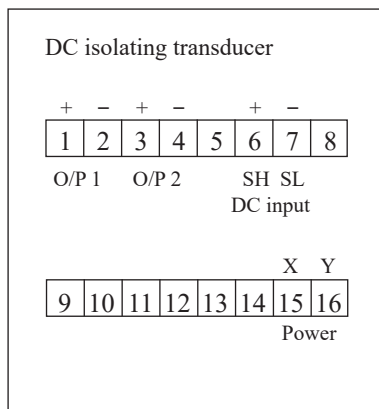

Dimension

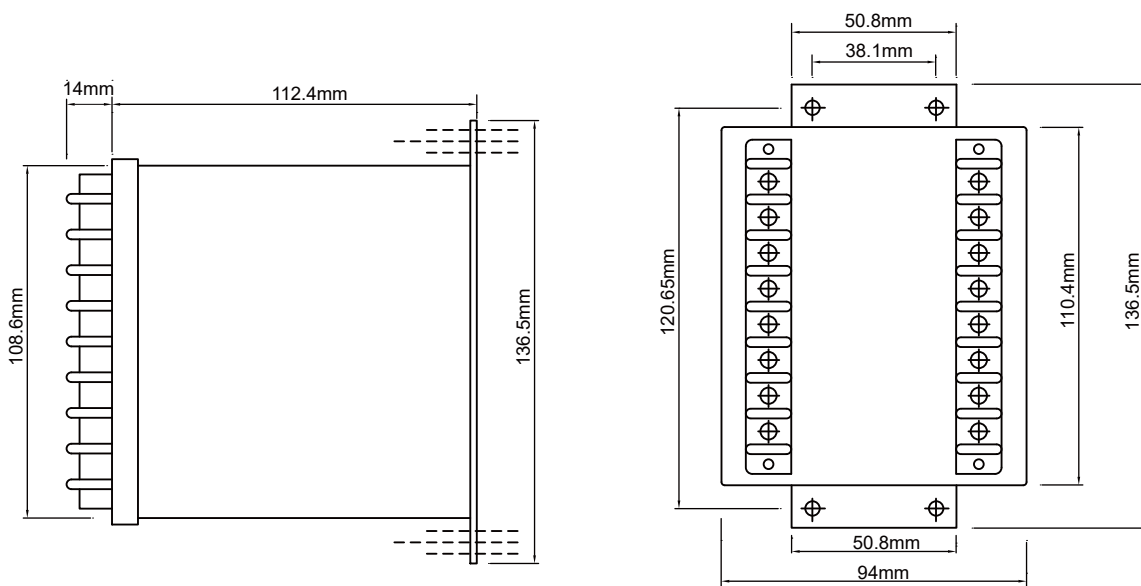

HSIANG CHENG ELECTRIC CORP.

4F., No.11, Ln. 235, Baoqiao Rd., Xindian Dist., New Taipei City 231, Taiwan

TEL : 886-2-2917-5865~9

E-mail : expo.sales@hc.com.tw

FAX : 886-2-2917-3946

http://www.hc.com.tw